

*The Engineering Professions Association
Of Namibia*

YOUNG ENGINEERS' CONSTRUCTION PROJECT

EPA BRIDGE BUILDING COMPETITION RULES

1. Each team will be allocated a working area and a standard material kit containing the following:
 - (a) 16 wooden dowels, app. 6mm diameter and 900mm long
 - (b) quick-setting glue
 - (c) one four-metre length of thin cotton string
 - (d) one set of wooden clothes pegs for "clamping" construction joints; the pegs may not be used as part of the bridge *
 - (e) one piece of hardboard on which to cut wood *
 - (f) one cutter *
 - (g) one hack-saw blade *
 - (h) one tape measure *

* These items are to be returned in good order and the pegs are not to be glued together. Please note that teams are to provide their own stationery for e.g. pencils, rulers, erasers, etc. for preparation and sketching purposes.

Please ensure that you do not cut into the working tables and do not remove the paper covering from the tables, as it prevents glue from adhering to the work surface. Each team is to clean up their area after completion of the bridge. No mess is to be left behind.

The use of non-electrical small hand tools, sandpaper clamps and weights is allowed. Should the venue allow for sufficient power points the use of hair-dryers will be permitted. Competitors are to ensure that they supply extension cables should the use of hair-dryers be permitted. Please note, should for any reason there be a discrepancy with any of the items above, the organisers' decision is final.

2. All models will be centrally loaded until they fail. Please pay considerable attention to the diagram showing how the loading apparatus projects through the sidewalls of the bridge (Figure 1). Ensure that no part of the bridge obstructs the loading apparatus, as this will disqualify your bridge. The loading apparatus will be made available on request for checking.
3. **NB:** All dimensions on the attached diagrams are in millimetres.
4. All bridges must conform to the following dimensions:
 - (a) the clear span (i.e. clear gap) under each bridge must be 650mm (Figure 2), i.e. the total bridge must be longer than 650mm
 - (b) each bridge must be able to support the loading apparatus (app. 4kg)
 - (c) maximum bridge width is 135mm (See Figure 3)
 - (d) minimum bridge width is 115mm (See Figure 3)
 - (e) maximum bridge height above the supports is 250mm (See Figure 2)
 - (f) maximum bridge depth below the roadway is 120mm (See Figure 3)
 - (g) no member used in the construction of the bridge may be longer than 600mm; you may not use a 900mm dowel in one length.
5. All bridges must provide for a 100mm wide x 100mm high minimum passageway along the entire length of the bridge. The loading apparatus must rest on the bridge at the roadway level. To test the roadway of your bridge, there are loose hardboard strip available. The hardboard should rest on the cross members. The hardboard strip does not form part of your bridge and may not be glued to the members.

Provision must be made for a minimum clearance of 100mm above the roadway to assist with the functioning of the loading apparatus. The maximum depth of the bridge below the roadway cannot exceed 120mm (See Figures 1 and 3).

6. The bridge will not be allowed to butt up against the vertical sides of the supports. Only "simple" supports will be allowed (See Figure 4).
7. Members of the bridge cannot be laminated together along the length of the members. The allowable overlapping of one member to another is 15mm. Two parallel members may be connected, using "spacers" (See Figure 5). Parallel members may be glued to each other only where they come into contact with cross members, or where spacers (of maximum length 15mm) are used. These spacers between two parallel members must be 25mm or more apart (clear distance, not centre-to-centre distance, see Figure 5).

There are no special rules that apply to the gluing of a joint where several members from different directions meet at the joint.

8. The string may be used in any manner, but may not be glued to a wooden member along the whole length of the member. The string may be knotted to members or glued at sporadic intervals not closer than 50mm.
9. Each model bridge will be inspected and any violations of the above rules can cause immediate disqualification. Alterations will not be allowed after inspection.
10. The order of testing will be decided by the judges. Bridges incapable of carrying the loading apparatus will be disqualified.
11. Evaluation of the bridges will be taken as a combination of the following factors:

(a) the load carried by the bridge, divided by the mass of the bridge:	80 points
(b) ingenuity	10 points
(c) workmanship	10 points
12. The decision of the judges will be final and binding and all winning bridges may, after testing, be retained by the judges and may be subjected to further examination.
13. All scholars are to please wear their school uniform for the prize-giving.

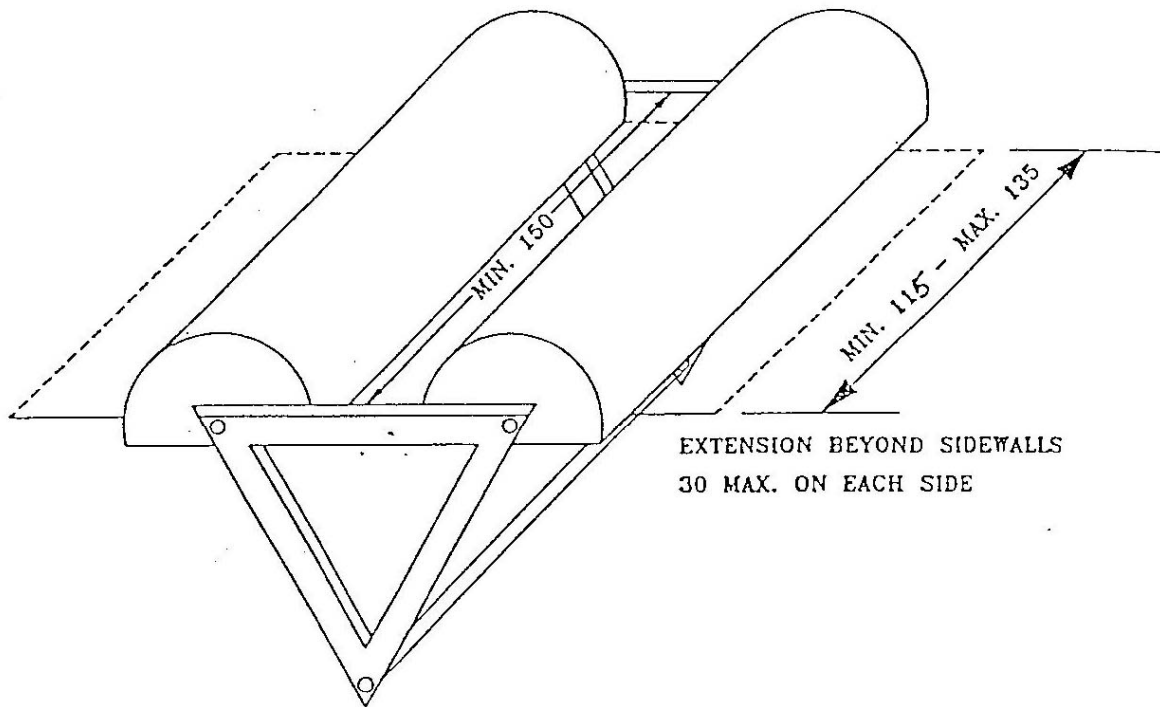

FIGURE 1(a)

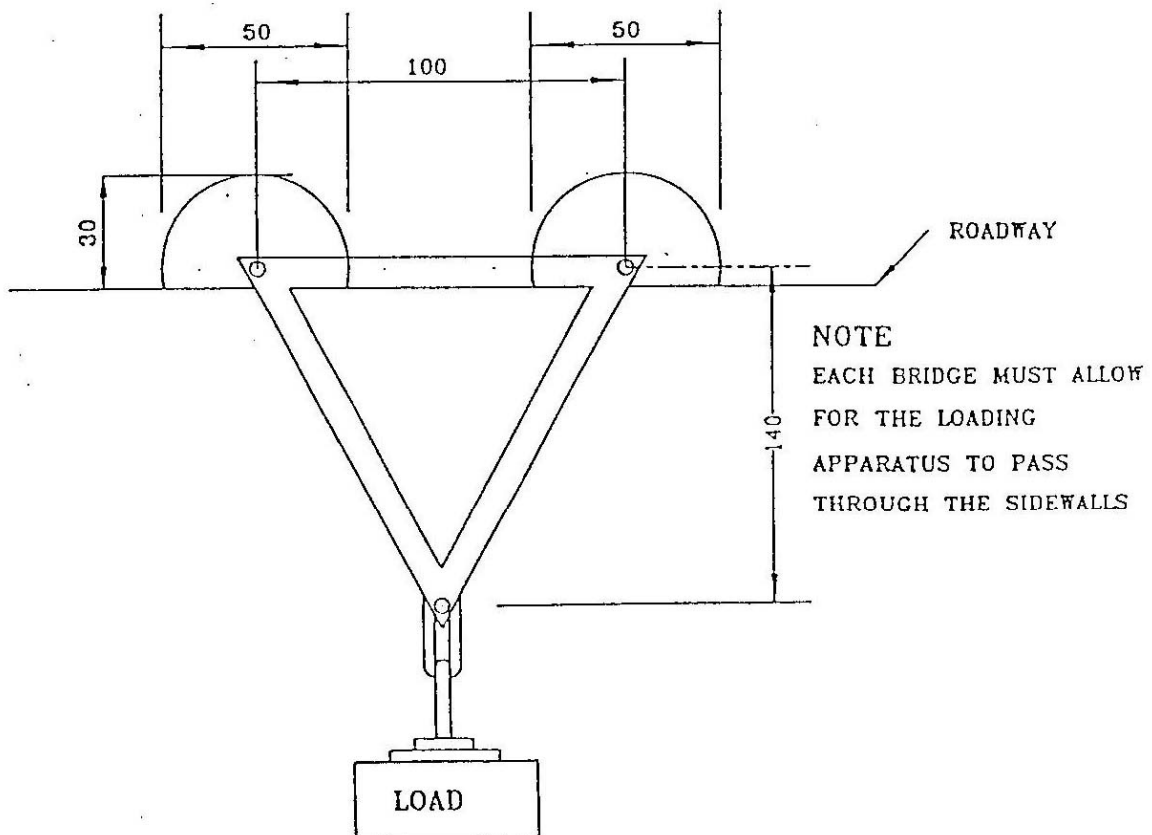

FIGURE 1(b)

LOADING APPARATUS

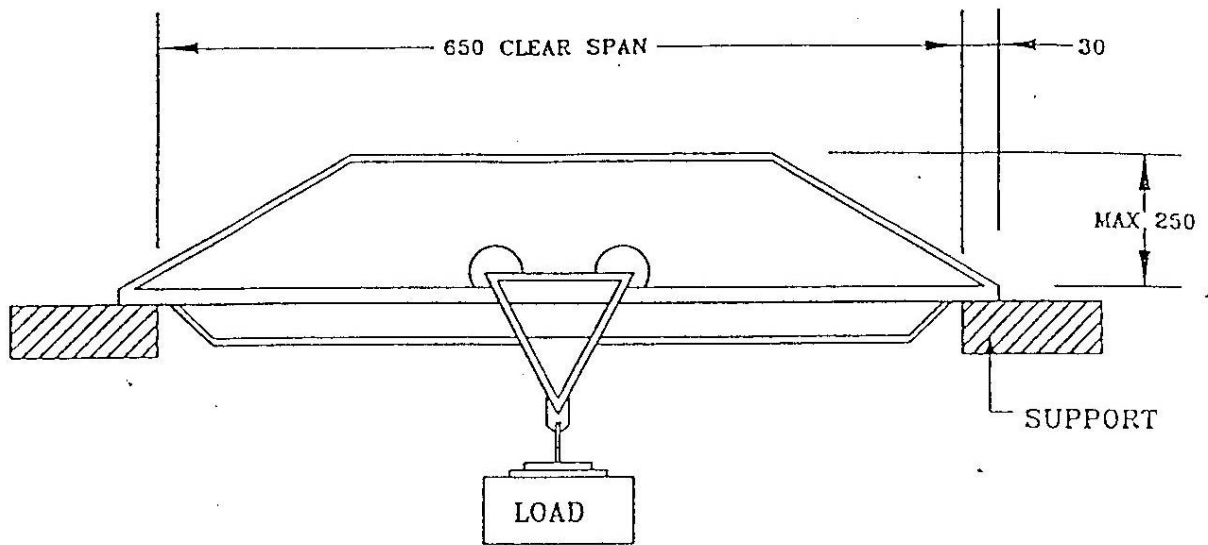

FIGURE 2

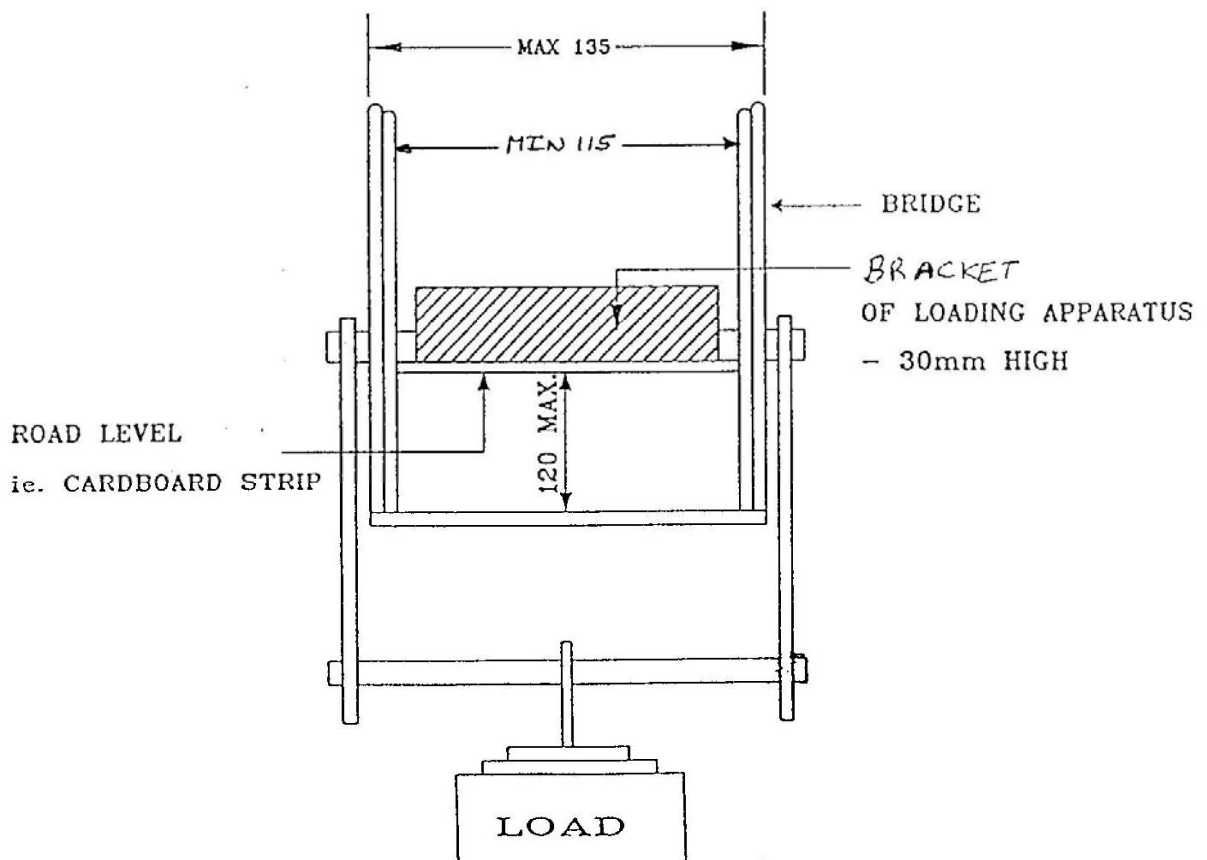

FIGURE 3

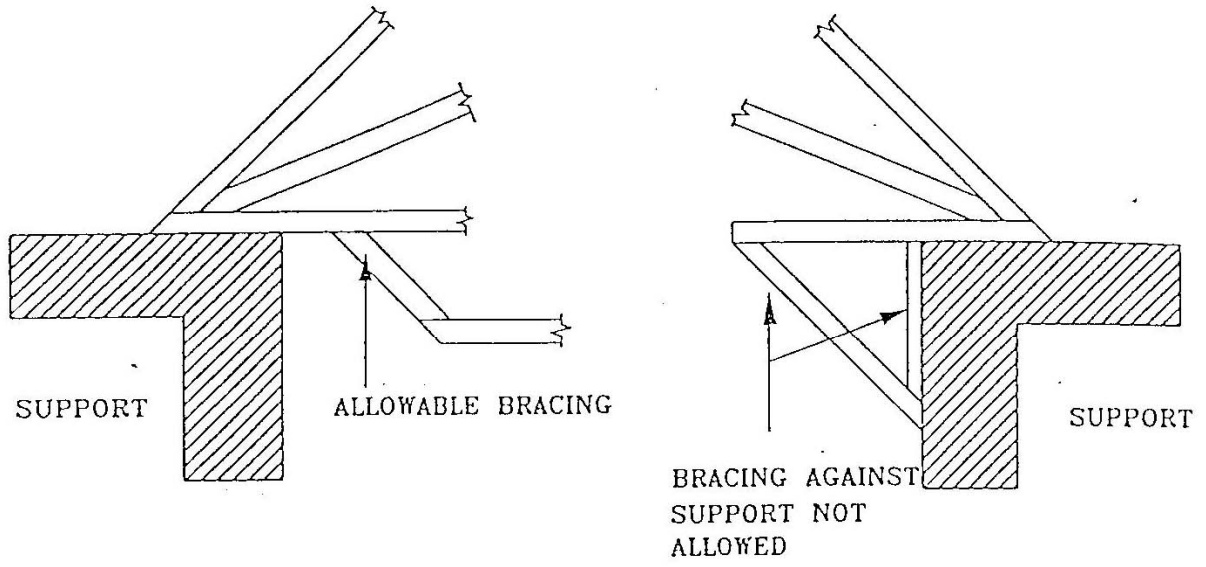

FIGURE 4

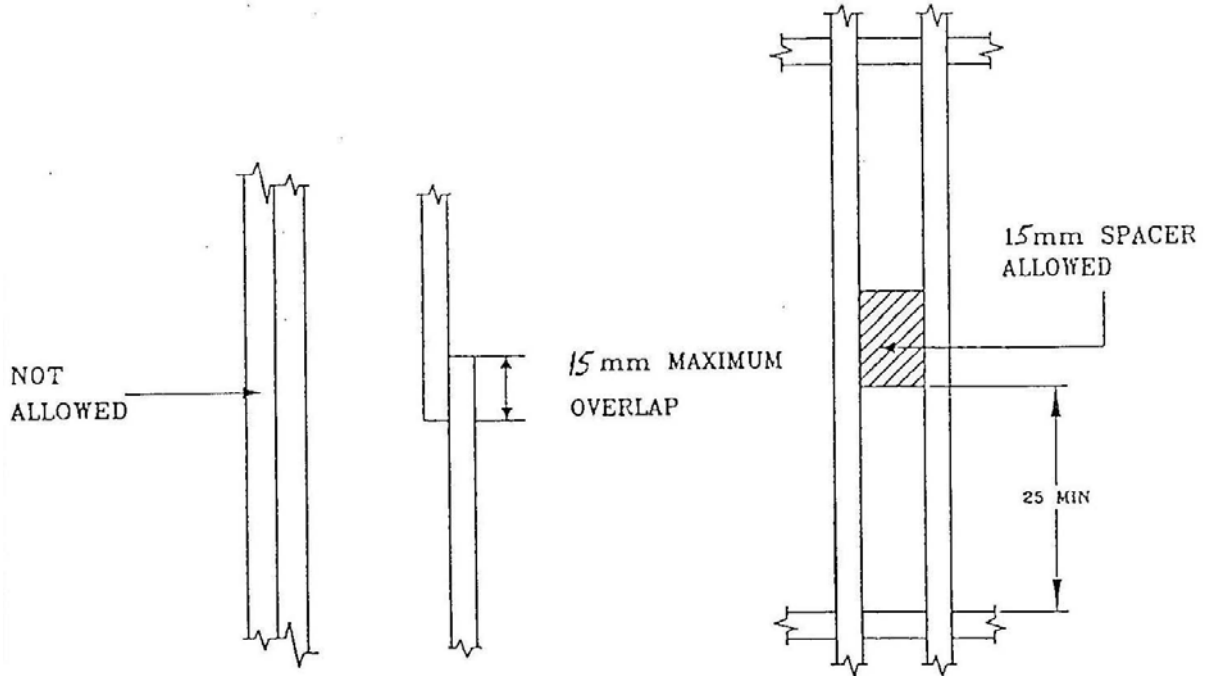

FIGURE 5