

YOUNG ENGINEERS

CONSTRUCTION PROJECT

1994

BRIDGE BUILDING COMPETITION

TEAM NO :

SCHOOL :

PREPARED BY:

WINDHOEK CONSULTING ENGINEERS
P O BOX 2484
WINDHOEK

TEL : 061 - 37728
061 - 38880

INDEX

	<u>Page</u>
1. SPONSOR	1
2. INTRODUCTION	2
3. PRIZES AND FINANCIAL ASSISTANCE	2
4. GENERAL RULES	2
5. SPECIFICATIONS	3
5.1 Hypothetical Case	3
5.2 Type of Bridge	3
5.3 Dimensions	4
5.4 Weight	4
5.5 Identification	4
5.6 Materials	4
6. EVALUATION	5
6.1 Judging Procedure	5
6.2 Test Procedure	5
6.3 Documentation	5
6.4 Aesthetics	6
6.5 Geometry	6
6.6 Ingenuity	6
6.7 Performance Testing	6
7. HINTS AND WARNINGS	7
8. SUMMARY	7
9. CONCLUSION	8

1. SPONSOR

To run this project each year requires a fair amount of funding. Without sponsorships the EPA would not be able to present this project to you and give you the opportunity to experiment with engineering technology.

We are pleased to announce that Grinaker Namibia Pty Ltd has sponsored this years competition.

The value of this project to our country, the schools and the pupils is underlined by the fact that the sponsor has readily provided the money and prizes for this competition. It demonstrates their interest in you as scholars and their commitment to the development of our country.

2. INTRODUCTION

Welcome to the Young Engineers Construction Project. We are very pleased that you are taking part in this competition which will not only benefit each individual team member, but will also stimulate technological growth in Namibia.

In constructing this bridge, you will experience engineering, you will learn more about many scientific principles and, most important, you are going to have fun.

Please read the instructions **VERY** carefully. The model must conform to all specifications otherwise it might not be able to be tested.

Now, just a short reminder of the basis of the project. The Young Engineers Construction Project is presented to you annually by the Engineering Professions Association of Namibia (EPA) to provide pupils with an awareness of the engineering profession and to promote technical education to the benefit of our country.

The contest epitomises the challenges of the new Namibia, the symbolic building of bridges between schools and communities and the engineering challenges faced by a new nation in the making. When the coverage on radio and TV is taken into account, it will be seen that we strive towards achieving several goals.

- Education of non-engineers about the work that civil engineers do
 - Enhancing the esteem in which civil engineers are held
- and just as important
- Improving the self-esteem in which civil engineers hold themselves

3. PRICES AND FINANCIAL ASSISTANCE

3.1 Each school that submits an entry of reasonable quality may claim N\$ 200,00 for project expenses - Grinaker

3.2 1st prize - N\$1 000,00 (team) and N\$1 000,00 (school) - Grinaker

2nd prize - N\$ 500,00 (team) and N\$ 500,00 (school) - Sponsor or Grinaker

3rd prize - N\$ 300,00 (team) and NS 300,00 (school) - Sponsor or Grinaker

3.3 Bursary : Three Grade 12 students will be chosen, based on their performance during judging, and invited to work on site at Grinaker Namibia for the week 29 August 1994 to 2 September 1994. All three may submit a bursary application (university or technician) - one will win the bursary, the other two will receive N\$500,00 cash each.

4. GENERAL RULES

All IGCSE/HIGCSE schools in Namibia are invited and encouraged to enter the competition. Two teams from each school may participate, each team consisting of 3 members.

The competition consists of the design and construction of a bridge to control specifications giving a general description of the project and providing parameters for the bridge type, geometry, strength, testing to be carried out, test loading and deflection criteria etc.

Besides the briefing for the science teachers at an INSTANT Workshop in May on this project, you may consult **ANYBODY** or **ANY SOURCE** you feel is necessary to complete your project. Assistance will be provided by the EPA organising committee throughout the project. However, please remember that these people have full-time jobs and a busy schedule. So please! Make appointments and be patient if you must wait a while to be helped.

You are required to make use of your own or your school's tools and equipment or request assistance from neighbouring schools to complete the project.

The materials (to be supplied by the school) are to consist of 1 x 1,220 m x 1,220 m x 4 mm plyboard and 1 x 250 ml Ponal express glue. The wood and glue could be

obtained from any hardware shop.

The judging of all entries will take place in Windhoek, on Saturday 16 July 1994, at the Rossing Foundation Centre, and teams will be expected to travel to Windhoek at own cost to present their entries.

The team will be required to present their model to a panel of judges. The models will be judged on documentation, aesthetics, ingenuity and geometry, deflection under load, total load etc. The teams must also be prepared to answer questions from the panel of judges..

5. SPECIFICATIONS

5.1 Hypothetical Case

You are to assume that being just qualified as an engineer and being newly appointed in your company, your first job in your new environment is to build a scale model of a road bridge for display and instruction purposes. A competition has also been advertised among the different branches of the company for the most ingenious model and your office management is convinced that the honours will eventually be their's.

You are to be assisted by other newly appointed engineers in the company and you are given the following brief by management.

The model is of a road bridge crossing a river in a rural area. The length of the bridge is 50m and is approximately 35m above the water level.

Your model will be judged on the following criteria :

- the performance of the bridge
- the correctness of geometric specifications
- the aesthetics of the bridge
- the ingenuity of the design
- the build quality of the bridge
- the documentation supplied with the model

5.2 Type of Bridge

The type of bridge should blend with the environment. The plan provided gives 3 examples of commonly used bridge types. You are not limited to these 3 types.

Notice that the bridges are supported only at the two ends and that there are no intermediate supports.

In your reports explain why you think that there are no intermediate supports and describe some instances other than a river crossing, where these bridges could be used. Remember to motivate your choice of bridges.

A test bench is being constructed by EPA. Your model will be placed on this bench when being judged.

5.3 Dimensions

The bridge must have the geometric dimensions correct. Any bridge too long or too short may not fit on the test bench. Remember the overall dimensions are 1 000mm long x 200 mm wide. The bridge will be placed on the bench to check dimensions.

5.4 Weight

The weight of the bridge will play a very important role in the judging of the bridge. The lightest model in relation to the load it can carry and minimum deflection will score the most points in this section.

5.5 Identification

Your model should be clearly marked with the name of the school and the team number which will be given to you on the day of the competition.

5.6 Materials

Only 1 x 1,220 m x 1,220 m x 4 mm plyboard and 1 x 250 ml Ponal express glue may be used to construct your bridge. It is clear that if different materials are used it will make the judging (especially the load testing) very difficult.

You will be penalised for all materials used other than those specified. You are however free to use your own cosmetic material such as paint or stickers, as long as it does not influence the structural strength of the bridge.

6. EVALUATION

6.1 Judging Procedure:

Your team will be required to present this model to a panel of 3 judges. The judges are chosen for their ability to encourage young scholars so there is no need to be afraid of them. They will ask many questions and they will be only too happy if they receive some answers.

The bridges will be evaluated for the following criteria.

Documentation & interview	20 points
Aesthetics	10 points
Geometry	10 points
Ingenuity & build quality	20 points
Strength performance	<u>40 points</u>
TOTAL	100 points

6.2 Test Procedure

The supports and the testing plate must be on the same level as shown on the attached figures. Only "simple" supports will be allowed. A 10mm stiff rubber matt, 20cm x 15cm will be placed in the centre of the bridge. A sheet plate will be placed on top of this to ensure an even spreading of the load. The hydraulic testing arm will push the plate. The diagram in figure 1 shows the area to be left clear to facilitate testing.

6.3 Documentation

Your documentation/report must be presented in a binder with your bridge.

The following must appear in your documentation :

- School name
- Team number (to be supplied)
- Names of the team members
- Name of teacher assisting the team
- Project name
- Index
- Project description
- Choice of Bridge

- Calculations
- Drawings
- References (Your must say who has helped you, books etc.)

The inclusion of all these is worth 10 points. Neatness and general impression and the verbal presentation by the team are worth another 6 points.

The last 4 points are for initiative in the documentation.

6.4 Aesthetics

Your model will be judged for neatness and overall proportions and balance. The appearance of the model will be judged and the points awarded will depend largely on the judges. Note that the team number must appear on your model.

6.5 Geometry

This section will be judged very strictly. If the bridge does not conform to the geometric specifications, it cannot be tested.

The maximum loss of points will be 10 for this section, but you must remember all points for performance will also be lost since the model will not be able to be tested.

6.6 Ingenuity and Build Quality

In this section the judges will be looking at the quality of the bridge and for any good ideas used in constructing the bridge. If you have any ideas as to how the performance of the bridge could have been improved if you had been allowed to use other materials or components, please do not hesitate to include these in your documentation.

6.7 Performance Testing

This section is purely analytical. The basis on which the strength of each model will be adjudicated is as follows :

- 6.7.1 The bridge will be loaded in 2,5kg increments up to a maximum of 50 kg, i.e. 20 points for 50 kg load carrying capacity. For any bridge that collapsed or deflected more than 20 mm before the load of 50 kg is reached, 10 points will be deducted.

2.7.2 For each bridge tested, the following value will be determined :

$$R = \frac{\text{load (kg) at 20mm deflection}}{\text{Mass of bridge (kg)}^{1.25}}$$

If the deflection under a load of 50 kg is less than 20 mm, R will be enhanced by the value

$$\left(\frac{20}{\text{actual deflection}} \right)^{\frac{1}{2}}$$

Points calculated by the following formula will then be added :

$$\frac{R \text{ for bridge in question} \times 40}{\text{Max } R \text{ for all bridges tested}}$$

7. HELPFUL HINTS AND WARNINGS

The bridge when finished should resemble a real life bridge. Attention must be given to all finished touches.

Be prepared when talking to the judges

Put effort into your documentation

Be well acquainted with your model

Make sure that all adjustments are done before testing

Make sure you understand the performance formulas

Most important - have fun!

8. SUMMARY

You must construct a model bridge according to the rules provided.

The judges' decision is final and will under no circumstances be discussed with any of the participants or interested parties. The winning bridges will, after testing, be retained by the judges and may be subjected to further examination.

9. CONCLUSION

You now have all the information.

Go ahead - and enjoy yourself !

The judging of entries of this competition will take place on Saturday, 16 July 1994, at the Rössing Foundation Centre in Windhoek.

In case you require any additional information, please contact the organising committee at the office, telephone numbers indicated below :

Fritz Jeske	Tel. (061) 33095	-	Bicon
Gunther Nolting	Tel. (061) 33095	-	Bicon
Dirk van der Merwe	Tel. (061) 37728	-	WCE
Gys Joubert	Tel. (061) 37728	-	WCE
Graham Watermeyer	Tel. (061) 220600	-	Grinaker

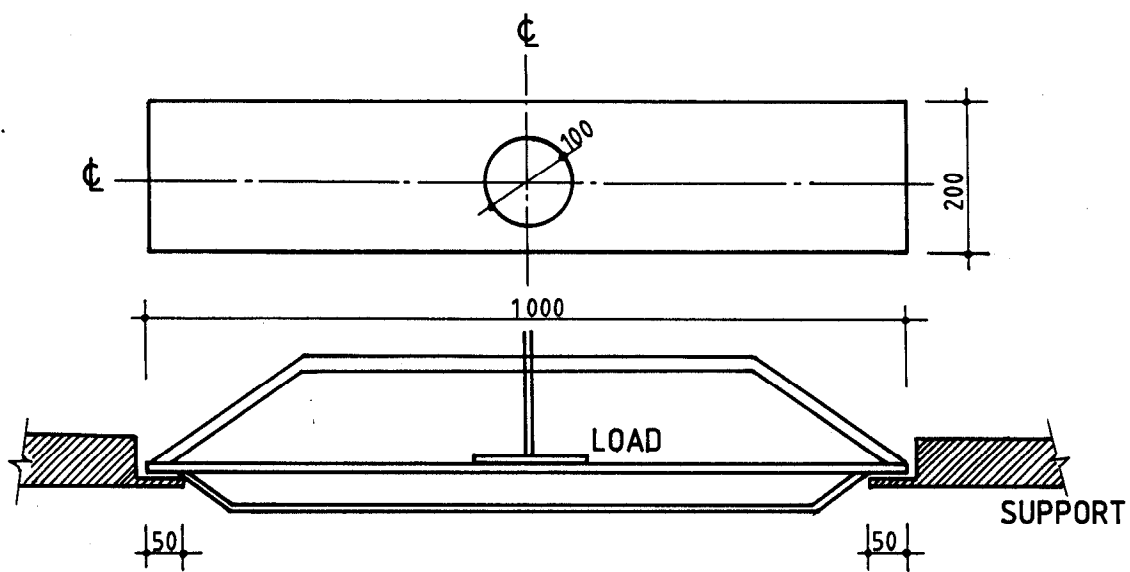
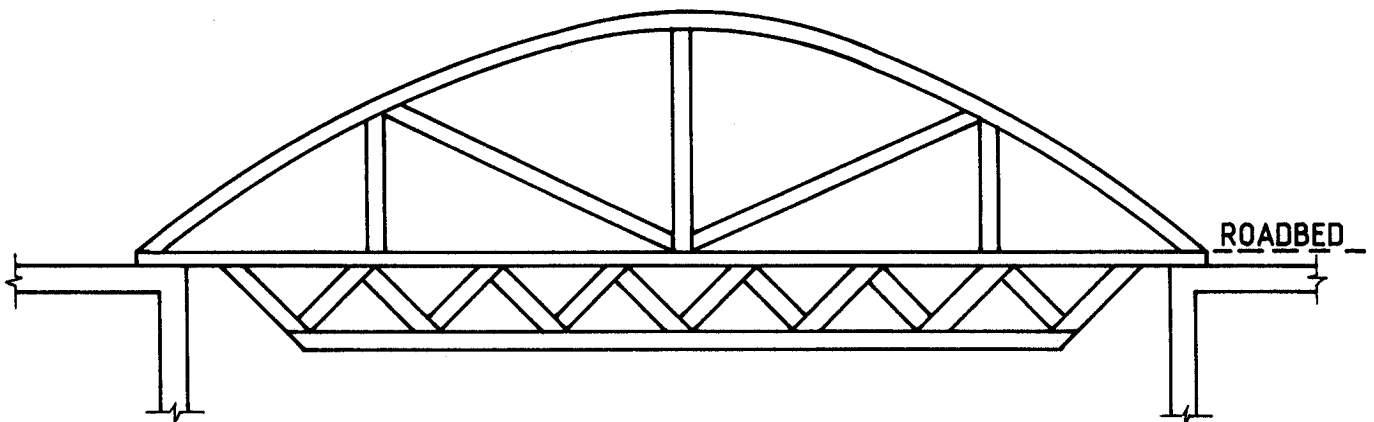
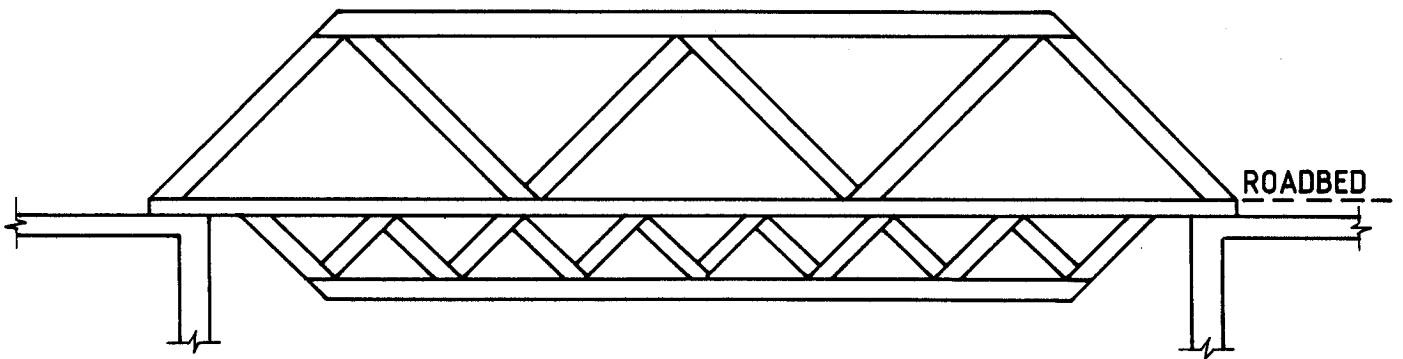
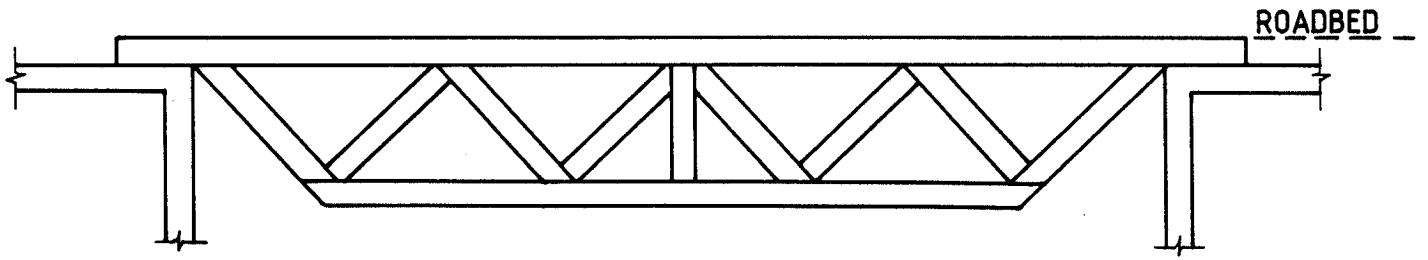

FIGURE 1



SAMPLE IDEAS

EPA CIVIL DIVISION

THE YOUNG ENGINEERS BRIDGE BUILDING COMPETITION

NAME OF SCHOOL :

ADDRESS :
.....
.....

TEL NO :

FAX NO :

RESPONSIBLE TEACHER :

TEAM MEMBERS :

1.
2.
3.